

# ZF W650

## TECHNICAL DATA SHEET

---

### ZF 650 SERIES PRODUCT DETAILS



#### Description

- Reverse reduction marine transmission with hydraulically actuated multi-disc clutches
- Robust design also withstands continuous duty in workboat applications
- Fully works tested, reliable and simple to install
- Compatible with all types of engines and propulsion systems
- Design, manufacture and quality control standards comply with ISO 9001

#### Features

- Durable cast iron construction
- Case hardened and precisely ground gear teeth for long life and smooth running
- Output shaft thrust bearing designed to take maximum propeller thrust astern and ahead
- Compact, space saving design with increased bearing and clutch capacity for heavy duty, and matching oil cooler.
- Smooth and reliable hydraulic shifting with control lever for attachment of push-pull cable
- Suitable for twin engine installations (same ratio and torque capacity in ahead or astern mode)
- Emergency "get home" capability



# ZF W650

## RATINGS

Ratios	Power Factor		Input Power Capacity						Max. kW	Max. hp	Max. RPM
	kW/RPM	hp/RPM	kW	hp	kW	hp	kW	hp			
Medium Duty - Diesel			1800 RPM		2100 RPM		2300 RPM				
3.605*, 4.057, 4.531*, 5.138, 5.593	0.2576	0.3454	464	622	541	725	592	794	670	898	2600
6.417*	0.2346	0.3146	422	566	493	661	540	724	610	818	2600
Continuous Duty - Diesel			1600 RPM		1800 RPM		2100 RPM				
3.605*, 4.057, 4.531*, 5.138, 5.593	0.2487	0.3335	398	534	448	600	522	700	647	867	2600
6.417*	0.2105	0.2823	337	452	379	508	442	593	547	734	2600

\* Special Order Ratio

# ZF W650

## DIMENSIONS

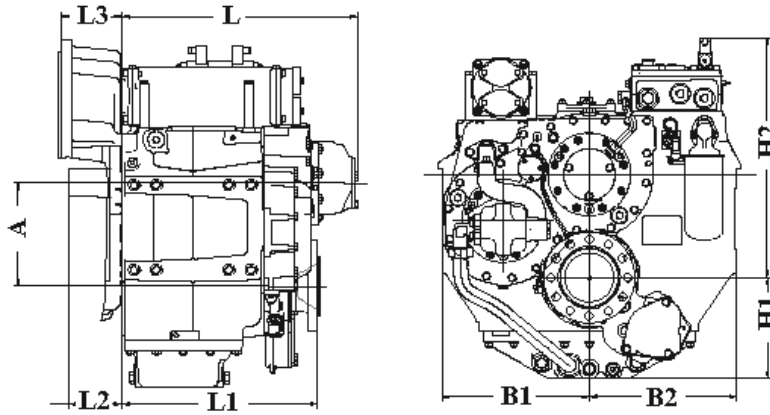

A	B1	B2	H1	H2	L0	L1	L2
Millimeter (mm)							
365.0	355.0	355.0	340.0	652.0	517.0	390.0	99.0
Inch (in)							
14.37	13.98	13.98	13.39	25.67	20.35	15.35	3.9
Weight (kg)		Weight (lb)		Amount of Oil (l)		Amount of Oil (qt)	
561		1237		26.0		27.6	

## BELL HOUSING DIMENSIONS

Name	A		B		C		L3		Bolt Holes		
	mm	in	mm	in	mm	in	mm	in	No.	Diameter	
										mm	in
SAE 0	647.7	25.5	679.45	26.75	711.2	28.0	100.0	3.94	16	13.49	0.53
SAE 1	511.18	20.13	530.23	20.88	552.45	21.75	100.0	3.94	12	11.91	0.47

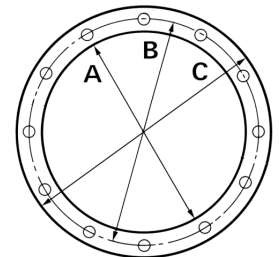

## OUTPUT FLANGE DIMENSIONS

A		B		C		D		Bolt Holes		
mm	in	mm	in	mm	in	mm	in	No.	Diameter (E)	
									mm	in
279.4	11.0	228.6	9.0	152.35	6.0	22.0	0.87	8	24.2	0.95



# GENERAL INFORMATION

---

## Duty Definitions

### Pleasure Duty

Highly intermittent operation with very large variations in engine speed and power.

Average engine operating hours limit:	500 hours/year 300 hours/year for mechanical gearboxes
Typical hull forms:	Planing
Applications:	Private, non-commercial, non-charter leisure activities, no racing

### Light Duty

Intermittent operation with large variations in engine speed and power.

Average engine operating hours limit:	2500 hours/year (for hydraulic transmissions smaller than ZF 2000 series, 2000 hours/year)
Typical hull forms:	Planing and semi-displacement
Typical applications:	Private and charter, sport/leisure activities, naval and police activities

### Medium Duty

Intermittent operation with some variations in engine speed and power.

Average engine operating hours limit:	4000 hours/year (for hydraulic transmissions smaller than ZF 2000 series and workboat ZF W2700 series, 3500 hours/year)
Typical hull forms:	Semi-displacement and displacement
Typical applications:	Charter and commercial craft (example: crew boats), and naval and police activities

### Continuous Duty

Continuous operation with little or no variations in engine speed and power.

Average engine operating hours limit:	Unlimited
Typical hull forms:	Displacement
Typical applications:	Heavy duty commercial vessels

---

## Technical Notes

### Duty Ratings

Ratings apply to marine diesel engines at the indicated speeds. At other engine speeds, the respective power capacity (kW) of the transmission can be obtained by multiplying the Power/Speed ratio by the speed. Approximate conversion factors:

- 1 kW = 1.36 metric hp
- 1 kW = 1.34 U.S. hp (SAE)
- 1 U.S. hp = 1.014 metric hp
- 1 Nm = 0.74 lb.ft.
- 1 Kg = 0.454 lb

Ratings apply to right hand turning engines, i.e. engines having counterclockwise rotating flywheels when viewing the flywheel end of the engine. These ratings allow full power through forward and reverse gear trains, unless otherwise stated. Contact your nearest ZF Sales and Service office for ratings applicable to gas turbines, as well as left hand turning engines, and marine transmissions for large horsepower capacity engines. Ratings apply to marine transmissions currently in production or in development and are subject to change without prior notice.

**NOTE:** The maximum rated input power must not be exceeded (see respective ratings in the technical data sheets).

### Safe Operating Notice

The safe operation of ZF products depends upon adherence to technical data presented in our brochures. Safe operation also depends upon proper installation, operation and routine maintenance and inspection under prevailing conditions and recommendations set forth by ZF. Damage to transmission caused by repeated or continuous emergency manoeuvres or abnormal operation is not covered under warranty. It is the responsibility of users and not ZF to provide and install guards and safety devices, which may be required by recognized safety standards of the respective country (e.g. for U.S.A. - the Occupational Safety Act of 1970 and its subsequent provisions).

### Monitoring Notice

The safe operation of ZF products depends upon adherence to ZF monitoring recommendations presented in our operating manuals, etc. It is the responsibility of users and not ZF to provide and install monitoring devices and safety interlock systems as may be deemed prudent by ZF. Consult ZF for details and recommendations.

### Survey Society Classification

In most cases, the maximum medium and continuous duty ratings permitted by ZF are accepted in full by major classification societies. If classification is required, contact ZF regarding proper procedures (also for yacht service and ice classifications service).

### Dimensions and Weights

Dimensions and weights refer to transmissions with bell housing (where appropriate) but excluding options such as: trolling valves, power take-offs, propeller shaft companion flanges, torsional couplings etc.

---

## Torsional Vibration and Torsional Couplings

The responsibility for ensuring torsional vibration compatibility rests with the overall propulsion system integration responsible party.

Compatibility check of torsional vibration must include excitations induced by engine governor. ZF cannot accept any liability for gearbox noise or for damage to the gearbox, the flexible coupling or to other parts of the drive unit caused by torsional vibrations. Contact ZF for further information and assistance.

For single engine powered boats, where loss of propulsion can result in loss of control, ZF recommends the use of a torsional limit stop. It is the buyer's responsibility to specify this option. ZF cannot accept any liability for personal injury, loss of life or damage or loss of property due to the failure of the buyer to specify a torsional limit stop.

ZF selects torsional couplings on the basis of nominal input torque at commonly rated engine speeds. Consult ZF for details concerning speed limits of standard offered torsional couplings, which can be below transmission limits. Special torsional couplings may be required for Survey Society requirements.